

Flat Pattern view
SCALE: 1:2

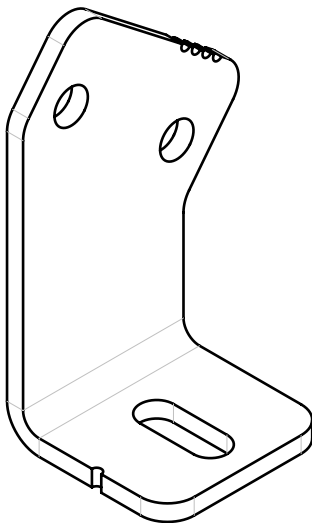
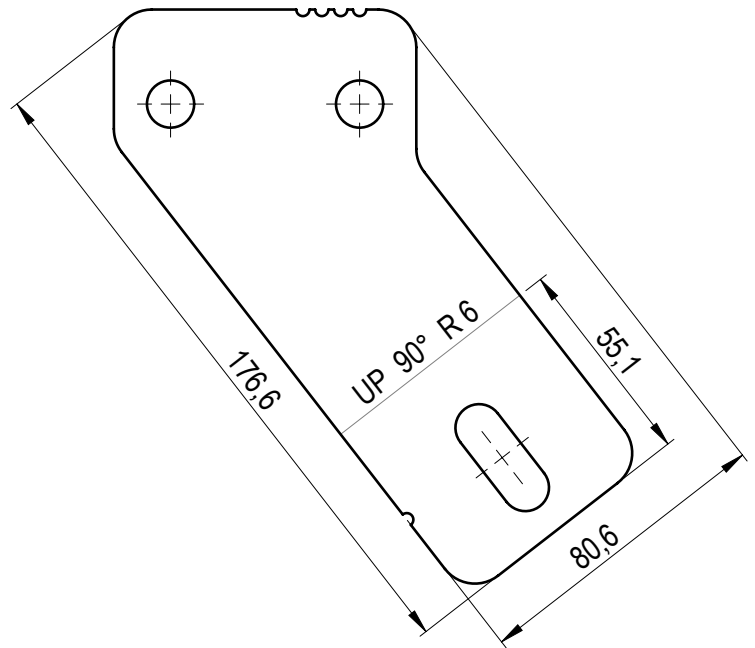
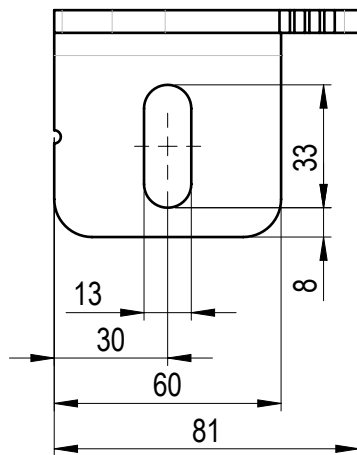

Other dimensions from .DXF file.

SHEET METAL INFORMATION	
Length, mm	176.6
Width, mm	80.6
Thickness, mm	6
Inside Bend Radius, mm	6
K-Factor	0.5
No. of Bends	1

	MATERIAL	WEIGHT	DEBURR AND BREAK SHARP EDGES DO NOT SCALE DRAWING		REVISION	DATE	
	S355J2	0.462 Kg				28.05.2025	
	SURFACE PROTECTION	MACHINING	THERMAL CUTTING	WELDING	SCALE	FORMAT	
	HDG EN ISO 1461	ISO 2768 mK	ISO 9013 221	ISO 13920 BF	1:2	A4	
	NAME	SIGNATURE	PART NO.				
Designed by	D. Dislers		105-09100-44			SHEET 1/1	
Drawn by	D. Dislers		DESCRIPTION				
Technical ref.			Left bracket 8U				